

FAIRBANKS NIJHUIS™ 7600 SERIES HORIZONTAL MULTISTAGE PUMPS

Fairbanks Nijhuis™ 7600 Series

Pentair's Fairbanks Nijhuis 7600 Series turbine pump brings more than a century of experience to a pinnacle. The 7600 Series pump is a multistage, horizontal, radially split pump for high pressure service.

With as many as 30-50% fewer stages than the competition, repairs are less costly and can be accomplished in the field. Its higher efficiencies allow for the use of smaller motors and less power consumption-another operational savings for the user. Fewer stages mean a shorter pump taking up less space.

Easy field alignment. Innovative design eliminates need for plate type thrust bearing. Thrust is taken in each stage.

Materials of construction options allow for the right material choice for your fluid. Options include cast steel, 316 SS and CD4MCu maximize life and MTBF. Investment cast bowls and impellers provide optimum surface finish and dimensional integrity for parts repeatability.

The 7600 Series pump is designed for service in salt water injection wells, pipeline service, reverse osmosis, boiler feed and other high pressure applications.

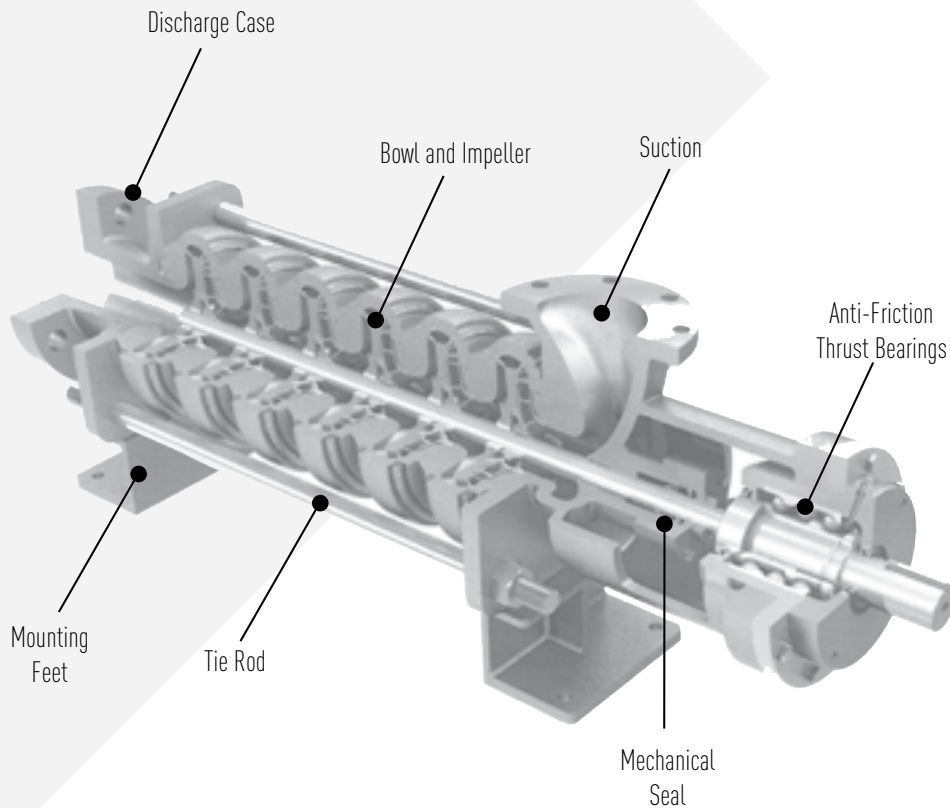

Pentair horizontal multistage pumps are available in pressures up to 2000psi (1400 mlc) and come in a variety of materials. This pump is ideal for surface pumping due to the smaller footprint, improved efficiencies, and lower maintenance costs than other competing H pump systems.

Dimensional Data

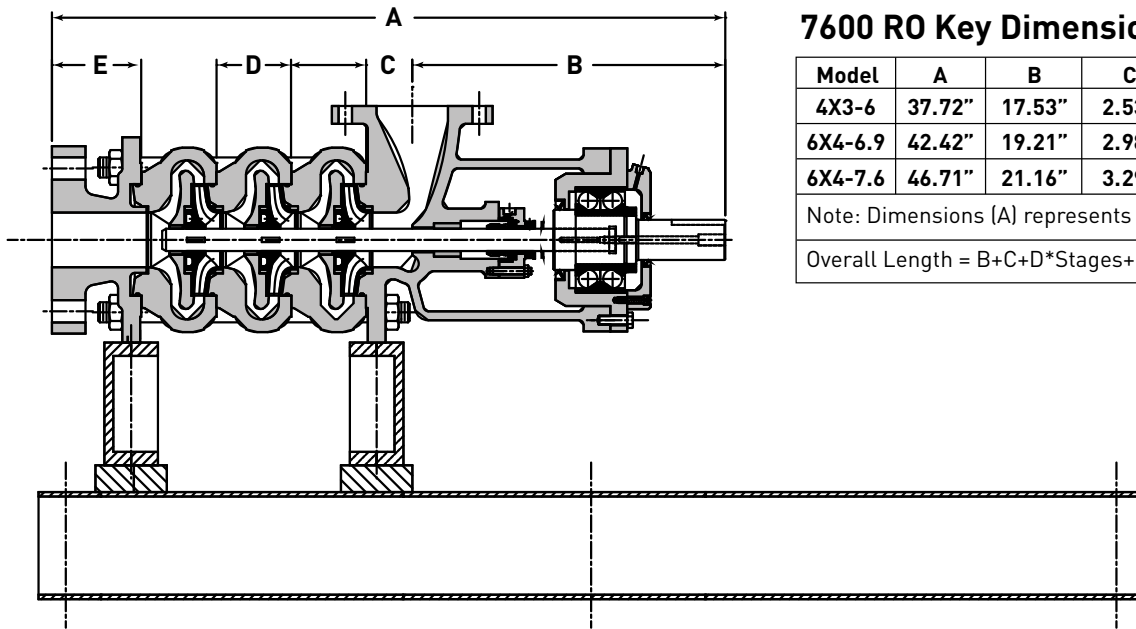

7600 R0 Key Dimensions

Model	A	B	C	D	E
4X3-6	37.72"	17.53"	2.53"	4.20"	5.00"
6X4-6.9	42.42"	19.21"	2.98"	4.83"	8.00"
6X4-7.6	46.71"	21.16"	3.29"	5.32"	8.42"

Note: Dimensions (A) represents a 3 stage unit.

Overall Length = B+C+D*Stages+E

Pump Features

- Patented design for higher efficiencies
- Fewer stages, shorter length, smaller foot print
- Field repairable
- Only the worn or damaged part needs to be replaced
- No plate type bearings or pressurized oil system
- Easily replaceable, anti-friction "thrust" bearing
- Easy field alignment
- Simpler mounting base than others
- Thrust balanced hydraulic design for minimal axial thrust

Range Chart RO-7600 Multistage Horizontal Pumps-3500 RPM

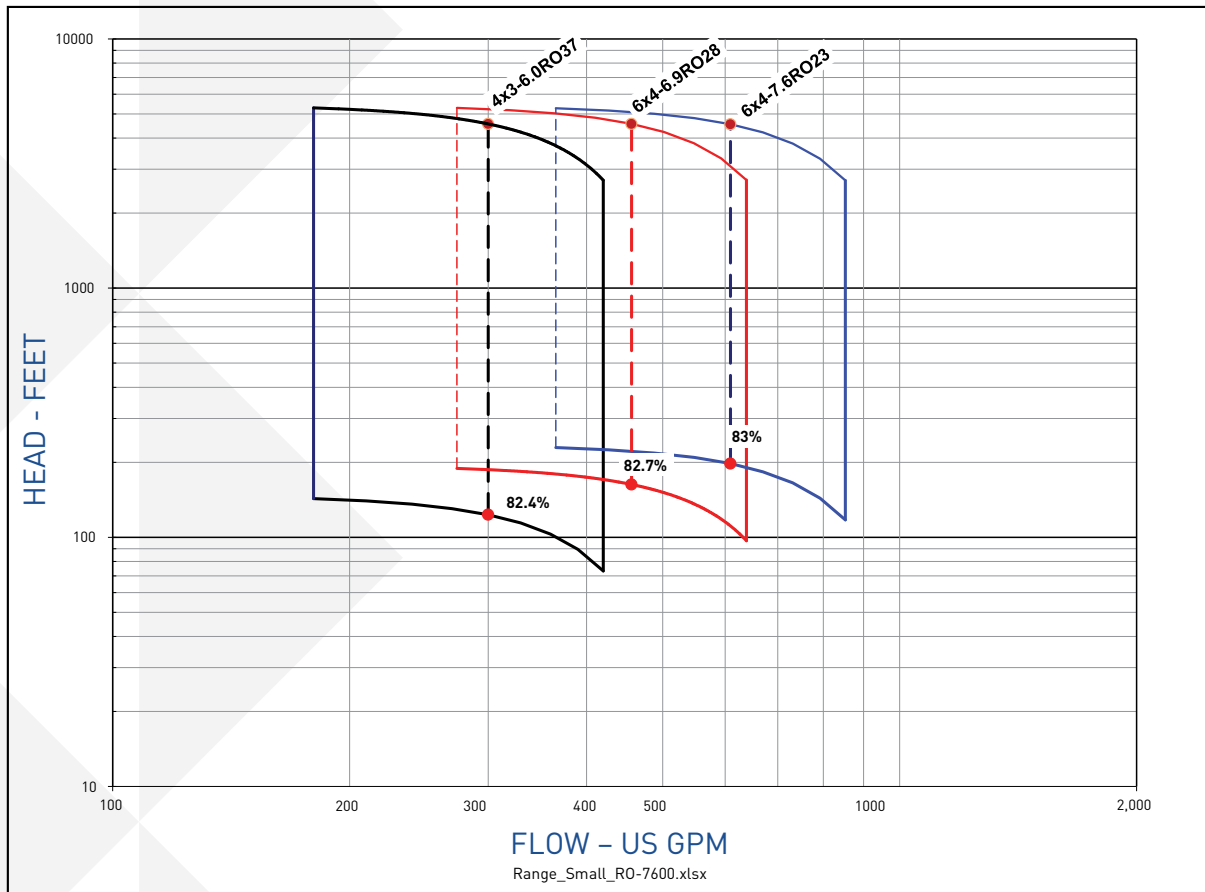

NOTE: Chart depicts a portion of what is available, please contact your local Pentair regional sales representative for more information.

Offering quality products such as: Vertical Turbine Can pumps, reciprocating pumps, ANSI end suction pumps, split case pumps, sump pumps, submersible pumps and the Myers® line of Aplex Series pumps, Pentair's family of products have served this industry throughout the years with reliability and confidence.

AURORA®
FAIRBANKS NIJHUIS™
MYERS®

www.AuroraPump.com | www.FairbanksNijhuis.com | www.femyers.com



3601 FAIRBANKS AVENUE, KANSAS CITY, KANSAS 66106 www.FairbanksNijhuis.com

Because we are continuously improving our products and services, Pentair reserves the right to change specifications without prior notice.
 FN11316BR 04/29/14 © 2014 Pentair Ltd. All Rights Reserved.